

DRILLED AND COUNTERBORED FOR STANDARD
M12 SOCKET HEAD CAP SCREWS

D

C

B

A

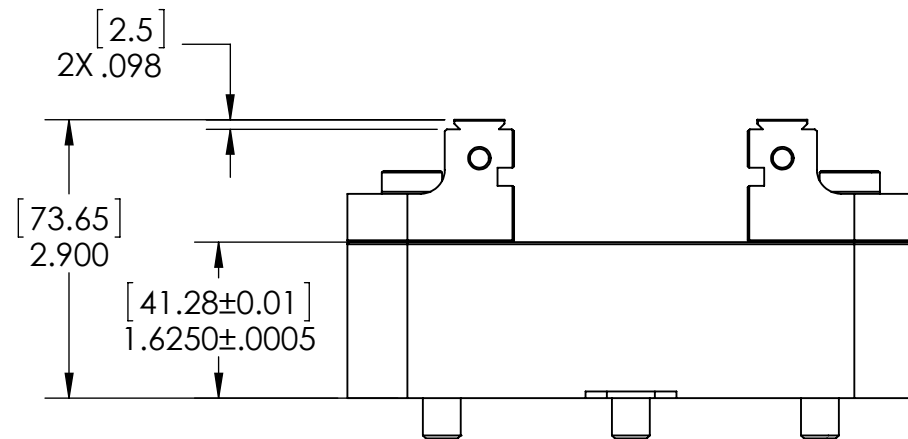
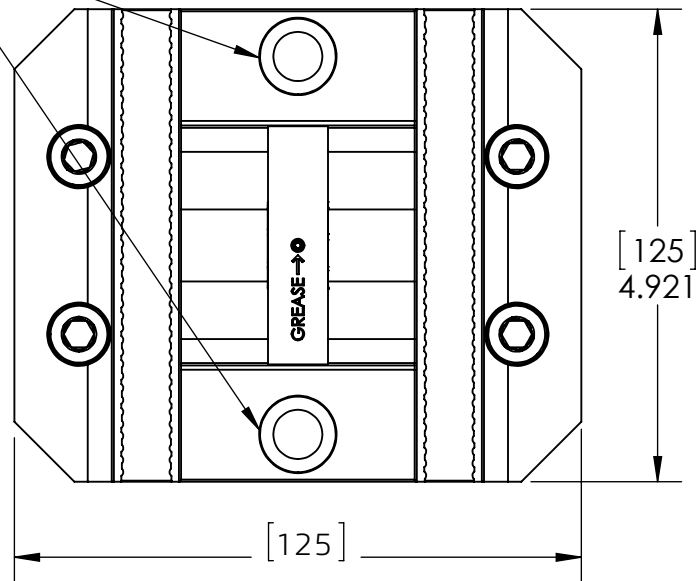

LOCATION BORES MEASURE $.3942 \pm .0002$ 2 PL
SHOWN WITH OPTIONAL 10MM LOCATING PINS

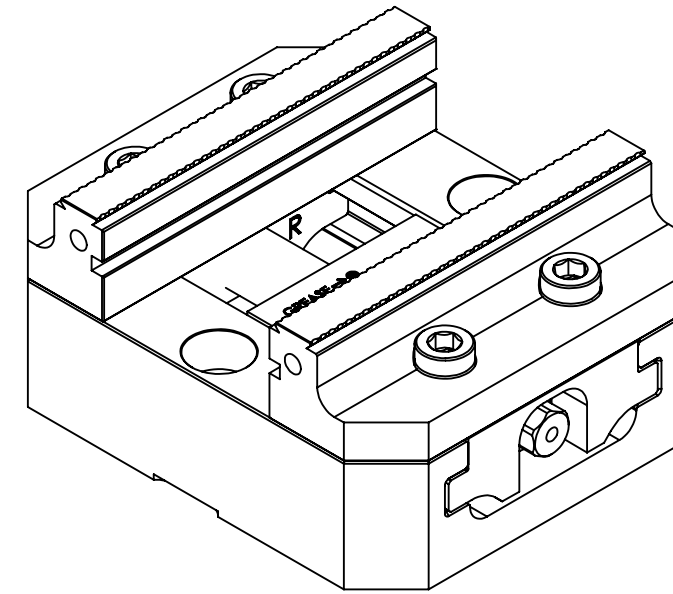
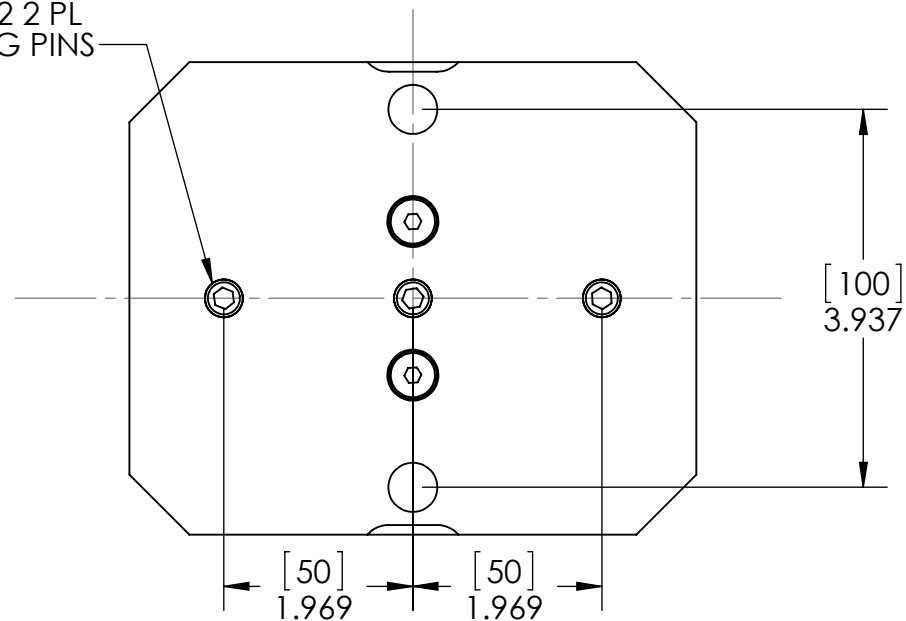

RECOMMENDED DIMENSIONS AND HOLE LOCATIONS FOR
CUTTING SOFT JAWS - BOTTOM SIDE SHOWN

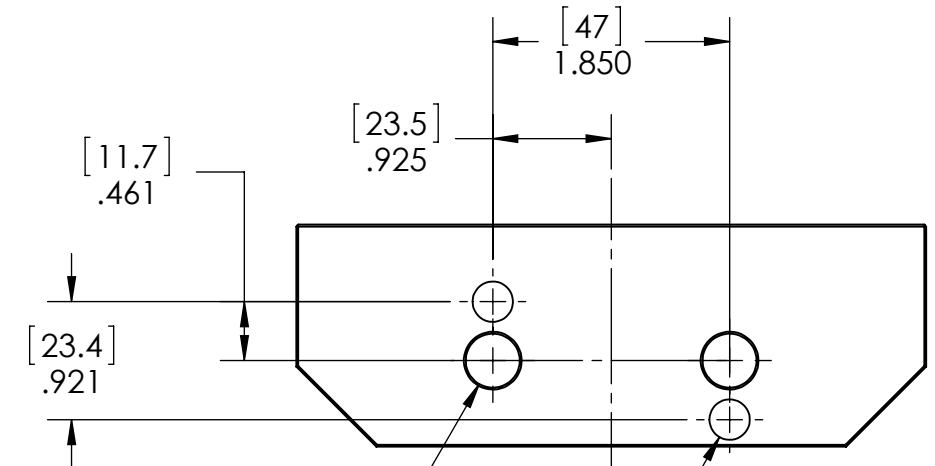

2X $\phi .422$ [10.72] THRU ALL
 $\phi .660$ [16.76] ∇ AS NECESSARY ON
FAR SIDE

2X $\phi .3155$ [8.01] $\pm .0002$ [0.01] $\nabla .2700$ [6.86]
WHEN USING REMOVABLE LOCATING PINS

$\oplus \phi .002$